

Aire Series

Hepa 14 Air Purifier USER MANUAL



PRODUCT OVERVIEW

Before using this product, please read the manual carefully and keep it for future reference.

Note: The illustrations of the product, accessories, and user interface in this user manual are for reference purposes only. The actual product and its functions may vary due to product enhancements.

What's included in the box: Air purifier Main Unit, Power Adapter, User Manual.

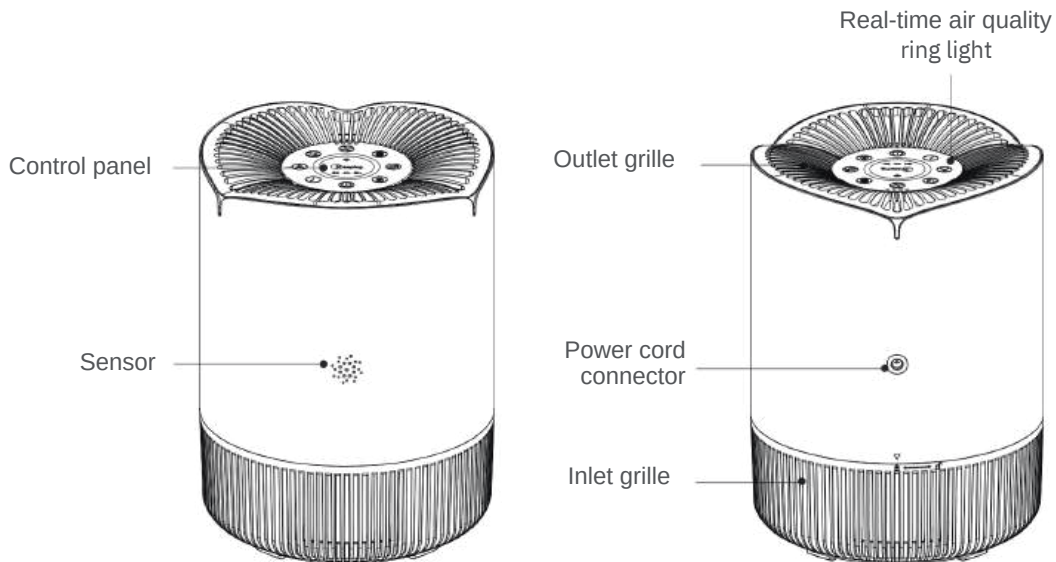

PRODUCT OVERVIEW



Regular Version

How to use

CAUTION

1. Remove the plastic bag from the filter before operating.
2. Power Adapter inside of the filter.

Connect to an outlet

Connect one end of the power adapter to the power cord connector and plug the other end into an outlet.

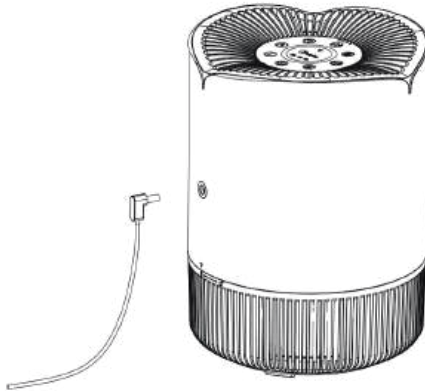

Tips

For better purification, it is recommended to keep doors and windows closed when using the air purifier.

Standby Mode

After connecting to an outlet, the air purifier enters the self-test procedure, and then stay in the Standby Mode. The  button will be dim Red, while all of the other lights are off.

ON/OFF



Press the  button to power on (defaults to Automatic Mode) or to power off.

Fan Speed

Press the  button to change the fan speed while the air purifier is powered on. The Fan Speed changes one step at a time, cycling through Low, Medium, High to Turbo. Refer to the indicator status as below.

Speed	Low	Medium	High	Turbo
Indicator	•	••	•••	••••

Sleep Mode

Press  the button to enter the Sleep Mode. The  button will be highlighted in White. After 10 seconds all of the lights will go off. To reactivate the screen, simply touch any button.



Auto Mode



Touch the  button to enter the Automatic Mode. The air purifier will automatically adjust the Fan Speed according to the real-time air quality index.

Timer

Timer can be set from 2-4-8 H.

Child Lock

(1) Child Lock: Long press the  button for 3 seconds, the air purifier will enter Child Lock Mode. The  button will be highlighted in Red.

(2) Long press the  button for 3 seconds, the child lock mode will be unlocked. The  button will be back to dim White.

Light OFF ☀

Press the ☀ button, all of the lights on the control panel will be turned off. To light up the light, simply touch any button.

Filter Replacement 🗑

When the filter service life reaches the set time (approximately 6 months), the icon will highlight in red, reminding the user to replace the filter.

Please refer to the diagram on the right. First, unplug the power adaptor and place the purifier upside down on a table. Then, rotate the air inlet grille counterclockwise and remove it to access the old filter. Replace the old filter with a new one and secure the inlet grille by turning it clockwise until it locks in place according to the positioning mark.

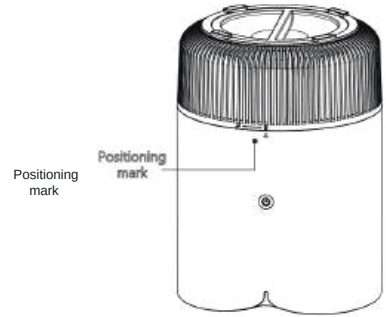

Reset Filter 🗑

Long-press the 🗑 button for 3 seconds. Afterward, all the panel lights on the control panel will flash for 3 times, and the 🗑 button will highlight in white. At this point, the filter life is be reset.







Air Quality Indicator

Three-color lights change colors according to the real-time air quality.

Indicator light	Air quality	PM 2.5
Green	Good	0-35 ug/m ³
Yellow	General	36-75 ug/m ³
Red	Bad	≥76 ug/m ³

WiFi(Optional)

How to connect APP

Long press the  button for 5 seconds to enter the  distribution mode when the air purifier is powered on. (ensure that the unit power-on switch button is illuminated with a white light) . The  icon will flash for 2 minutes. If the  is connected successfully, the  icon will light up. If the WiFi is not connected successfully within 2 minutes, the air purifier will exit the  distribution mode.

Note: The air purifier, mobile phone and router must be in the same network. Only 2.4GHz WiFi network is supported here.



Take out the air purifier, connect to the power outlet, and turn on the air purifier.

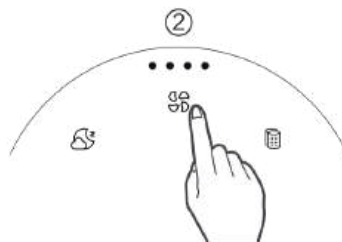

Long press the  button until the WiFi icon flashes.



Open Tuya APP to connect

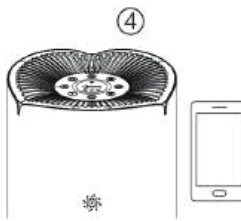

Enjoy the smart life

Basic Parameters

Product Name: Hepa 14 Air Purifier

Product Size: Ø200×275mm

Product Net Weight: 2.0kgs

Coverage Area: 20m²

Noise: ≤53dB(A)

Rated Voltage: DC24V

Calculated according to standard GB/T 18801-2015

Product Model: Aire

Particle purification efficiency: High

Formaldehyde purification efficiency: High

CADR Particles: 180m³/h

Rated Power: 23W

Warning & Safety Instructions

General Safety:

Turn off and unplug the purifier before moving it.

The purifier will not operate if the inlet grille is not installed correctly.

Maintain at least 10cm distance between air inlets and walls or other objects.

Regularly remove dust, hair, and debris from the outer mesh screen and air inlets to prevent bacteria growth and maintain airflow.

Cover the air outlet if the purifier will be unused for an extended period.

Electrical Safety:

Do not excessively pull, twist, or bend the power adaptor.

Only use the power adaptor provided with the purifier; do not use third-party adaptors.

Plug the adaptor into a suitable electrical outlet.

Always unplug the purifier before maintenance or moving it.

Replace damaged adaptors only with genuine parts from the manufacturer or authorized service.

Stop using the purifier immediately if it makes unusual sounds, emits bad odors, overheats, or the fan operates irregularly.

Usage & Handling:

Do not insert foreign objects into protective parts, movable parts, air inlets, or outlets.

Keep objects such as hair or fabrics away from air inlets/outlets.

Ensure sufficient ventilation when using gas-fueled appliances nearby to avoid carbon monoxide poisoning.

Do not pour liquids or throw powders into the air outlet.

Restricted Environments:

Do not use near open flames (candles, stoves, incense, lighters).

Avoid areas with high temperatures (electric heaters, irons, stoves).

Keep flammable objects away from the purifier.

Avoid unstable locations where the purifier may fall.

Do not use in extremely hot, humid, or damp environments (e.g., bathrooms).

Children & Supervision:

Children should not play with the appliance.

Cleaning and maintenance should not be performed by children without supervision.

Servicing Warning:

Risk of Electric Shock: Servicing should be performed by qualified personnel only.

Do not attempt any repairs other than what is described in the user manual.

Happie Warranty Information

Warranty Coverage:

Happie covers a one-month 1-to-1 exchange for any product defect under normal household use. No repair service will be offered. All claims must be submitted within this one-month period from the date of delivery.

Proof of Purchase Required

Warranty claims must be accompanied by valid proof of purchase (e.g., invoice or order confirmation). We will also verify the purchase record from our system.

Warranty Void Conditions

This warranty is void if:

- Product is damaged due to accident, misuse, abuse, or lack of reasonable care.
- Product has been disassembled, serviced, or tampered with by unauthorised personnel.
- The unit has been modified or altered from its original factory condition.
- Product is operated under unsuitable conditions or with the wrong voltage.
- The serial number is removed, altered, or defaced.

Shipping & Exchange Policy

- In the case of an approved warranty claim, Happie will arrange for a one-time exchange of the unit.
- This is a one-time exchange policy—no repeat replacements will be issued for the same unit.
- Customers may be responsible for delivery fees associated with the return/exchange, depending on the situation.

Filter Maintenance

To maintain optimal air quality, filters should be replaced at least every 6 to 12 months, depending on usage and environmental conditions. The filter change indicator will light up to remind you when it's time for a replacement.

Note: Filter replacement is not covered under warranty.

Support Contact

For product support or warranty enquiries, please contact our team via our service hotline: +65 9771 2788 .